

SIMFix® Pro/ST Steckverbinder für 7/8" Wellmantelkabel G24
SIMFix® Pro/ST Connectors for 7/8" Corrugated Cables G24



Montageanweisung / Assembly Instructions

für Kabel / for cable:
G24: RFA 7/8"-50 Draka
 RFX 7/8"-50 Draka
 LCF78-50JA RSF
 5228 7/8"-LD Eupen
 5228A 7/8"-LD Eupen
 HPL 50-7/8 Acome
 HFC 22D LS Cable
 LDF5-50A Andrew
 AVA5-50 Andrew
 FlexLine 7/8"R Leoni



SIMFix Pro

SIMFix ST

Bestell-Nr. P/N	Kurzbezeichnung/Description
J01020G0142	N-Kabelstecker / straight plug SIMFix Pro G24
J01021G0175	N-Kabelbuchse / straight jack SIMFix Pro G24
J01120G0084	7-16-Kabelstecker / straight plug SIMFix Pro G24
J01120H0084	7-16-Kabelstecker / straight plug SIMFix ST G24
J01121G0132	7-16-Kabelbuchse / straight jack SIMFix Pro G24
J01121H0132	7-16-Kabelbuchse / straight jack SIMFix ST G24
N00091A0014	Absetzwerkzeug / cutting tool
N00091B0019	Rotations-Absetzwerkzeug / rotation cutting tool
N00099A0000	Ersatzklingen-Set für / set spare blades for N00091A0014
N00099A0007	Ersatzklingen-Set für / set spare blades for N00091B0019

Achtung: Die Messer sind sehr scharf. Das Werkzeug ist vorsichtig zu handhaben. Es wird empfohlen, Arbeitshandschuhe zu tragen.
Attention: The blades are very sharp. The tool is to be handled with care. It is recommended to wear working gloves

Empfohlene Werkzeuge / Recommended Tools:

- Absetzwerkzeug / Cutting Tool **N00091A0014**
- Messer / knife (N00080A0003)
- Gabelschlüssel SW32 / Spanner 32af
- Gabelschlüssel SW27 / Spanner 27af
- Gabelschlüssel SW7 / Spanner 7af (9/32")
- Innensechskant 2 / Hexagon socket 2 (5/64")
- Schraubendreher 0,8x4 / Screwdriver 0,8x4

Anbindemöglichkeit
Hole for tie-on



Oder / or:

Rotationswerkzeug für
Elektroschrauber /
rotation cutting tool for power drill
N00091B0019



1 Kabelmantel mit Messer entfernen
Remove sheath with knife



3 Drehen ohne Zusammendrücken
Rotate tool without pressing tool jaws together

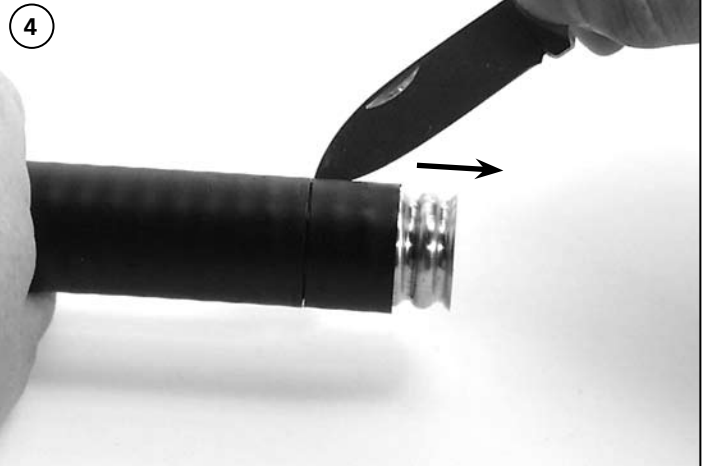

5

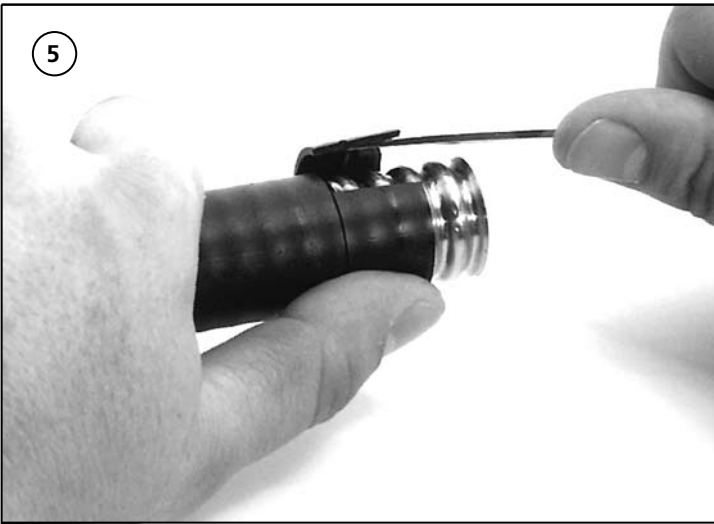

6

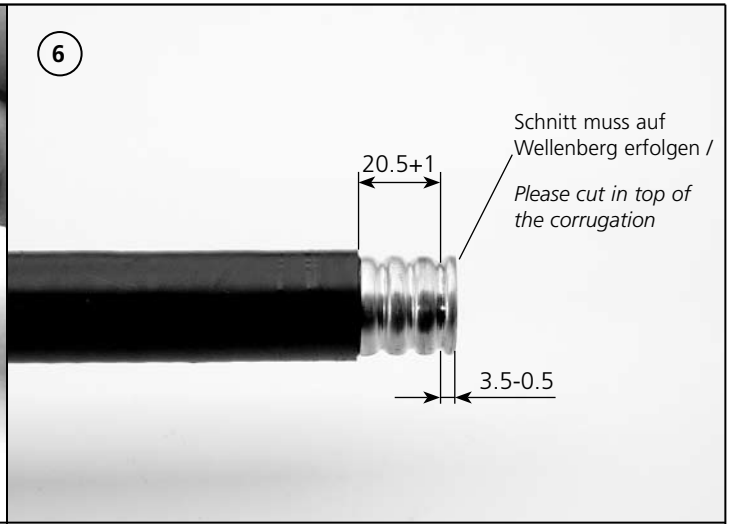

7



8



9



10



11



Gabelschlüssel 1xSW32 & 1xSW27
Spanner 1x32af & 1x27af
Empfohlenes Anzugsmoment 35 Nm /
recommended torque 35 Nm

Nach Kabelvorbereitung mit Rotationswerkzeug (N00091B0019) werden nur Schritte 6 bis 10 benötigt /
After preparing the cable using the rotation cutting tool (N00091B0019) follow assembly steps 6-10

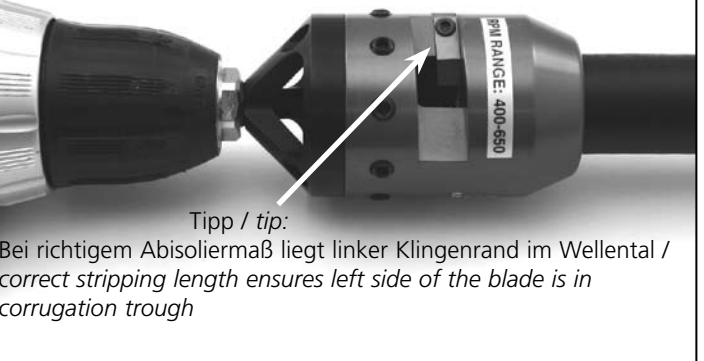

Kabeleinführung bis Anschlag über Kabelende (unter leichtem Drehen) ziehen. Kabeleinführung wieder nach vorne schieben, so dass Federkorb im Gehäuse verschwindet. / Whilst turning the cable entry slide it onto prepared cable until it butts against the sheath. Then pull it forward until it rests in a trough and the housing covers the spring bushing.

Achtung: montierte Steckverbinder nicht durch Biegen des Kabels mechanisch belasten / Take care, that the assembled connector is not mechanically stressed by bending the cable

Hinweis
Please note

*Bei Montage mit dem Steckgesicht nach unten in frostgefährdeten Gebieten wird die zusätzliche Verwendung eines Klebeschumpfschlauches oder selbstverschweißenden Klebebands empfohlen.
*When the connector is installed with the interface facing downwards, we recommend the additional protection of adhesive shrink-sleeving or self-amalgamating tape. This recommendation is only necessary for environments where (heavy) frost is likely.